

diagrams of the  
**PORTAL HALL**

# THE MALTESE CROSS & THE PENTAGRAM

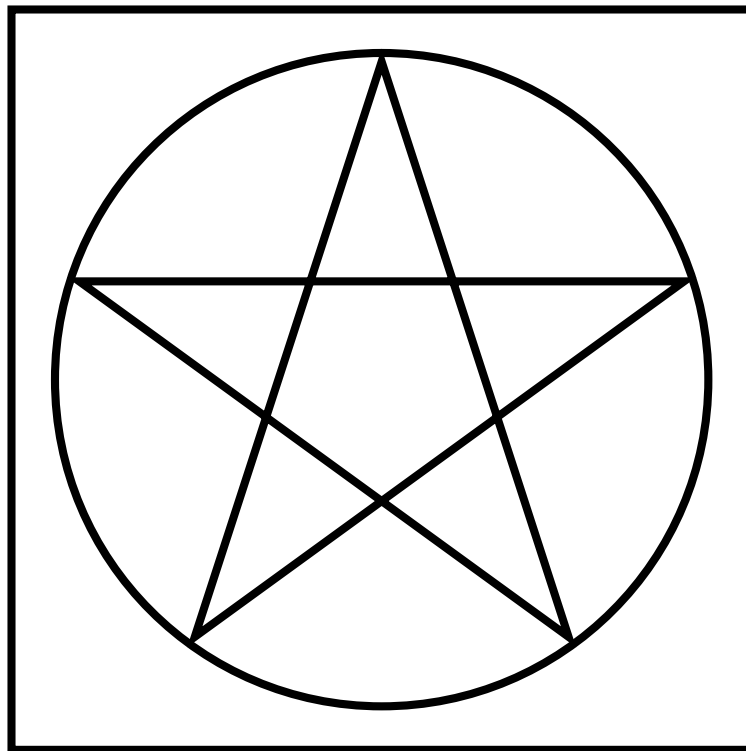
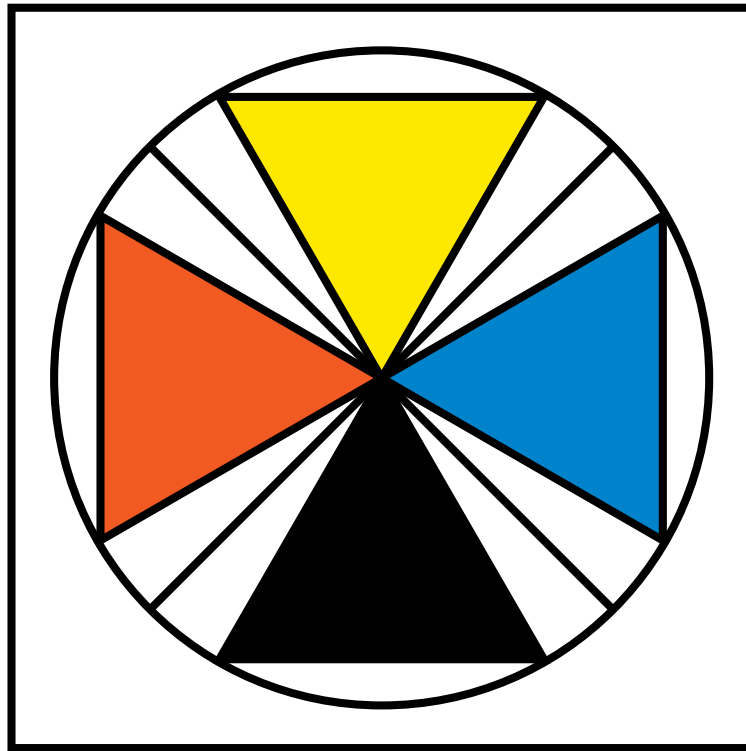

The Cross of Four Triangles called the Maltese Cross, is a Symbol of the Four Elements in balanced disposition. It is here given in the colors of the King scale and it is assigned to the Four Sepheroth of the Halls of the First Order. It is the Cross which heads the Praemonstrator's Wand who represents the Fourth Sepherah Chesed. Four is also the Number of Jupiter whose Path unites Chesed to Netzach. This Cross is therefore a fit emblem for a Philosophus of the Grade of 4=7.

# THE THREE DIRECTIONS FROM AIN INTO MATTER

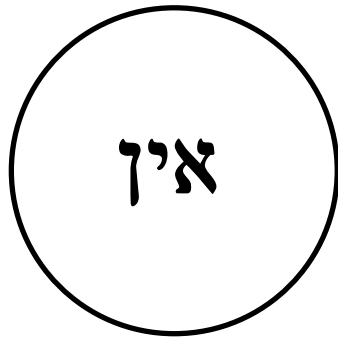

•  
The Point

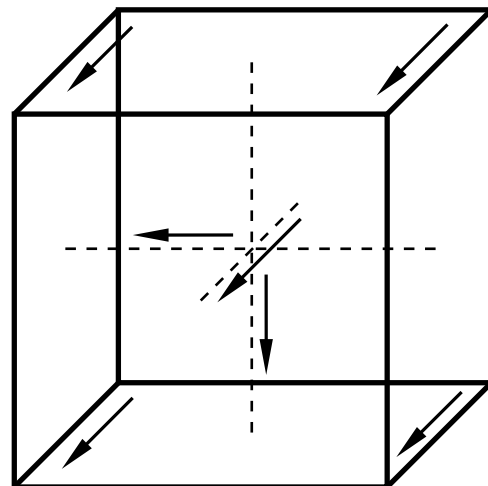
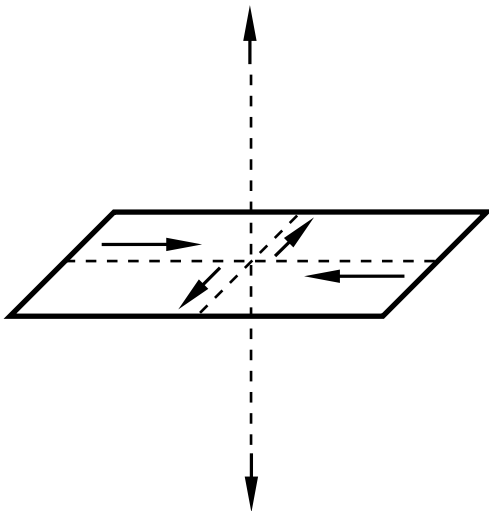
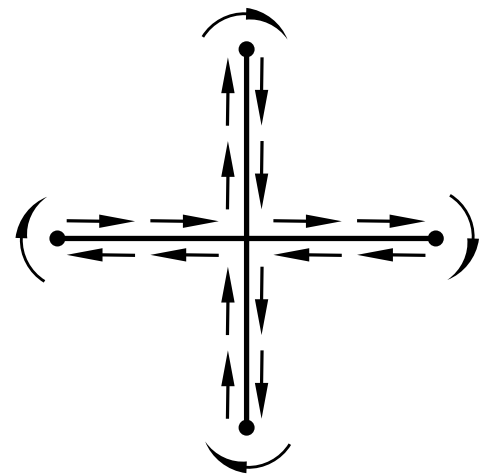
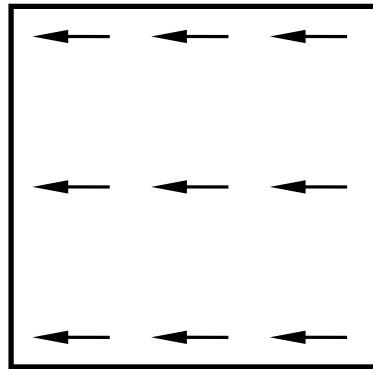

In this diagram are presented the Circle, the Point, the Line, the Cross, the Square and the Cube. For the Circle is the Abyss, the Nothingness, the AIN. The point is Kether. Now the Point has no dimension, but in moving, it traces the Line. This gives the first number—Unity—yet therein lies duality unmanifest, for two Points mark its ends.

The movement of the line makes the Plane or Square thus: The motion of the Point at square angles to its first direction and intersecting it makes the Cross. So therefore are the Square and the Cross but one Symbol, deriving from the Circle and the Point.

# DIAGRAM OF MALKUTH

Symbol of Malkuth

Root of  $\aleph$  Path  
 $\triangle$  of  $\nabla$

$\text{ת} \quad \text{ו} \quad \text{כ} \quad \text{ל} \quad \text{מ}$   
 $400 + 6 + 20 + 30 + 40$   
 $= 496$



Root of  $\psi$  Path  
 $\triangle$  of  $\nabla$

Root of  $\aleph$  Path  
 $\nabla$  of  $\nabla$

$\nabla$  of  $\nabla$

496 = 1  
 2 x 248  
 4 x 124  
 8 x 62  
16 x 31  
 31

496 = Sum of its  
 compound parts

6 = 1 + 2 + 3  
 = Sum of its parts

10 = 1 + 2 + 3 + 4  
 = Sum of its parts

4 Numbers

Here is shown the Occult Symbol of Malkuth, the Tenth Sepherah. It is in Four parts, corresponding to the Maltese Cross. They are Fire of Earth, Water of Earth, Air of Earth, and Earth of Earth, as indicated by the Symbol. They correspond to the Four Halls of the First Order, which in one sense, never leaves Malkuth, being the Halls of the Four Lowest Sepheroth of Malkuth in Assiah. Upon them is surcharged a white Hexagram in a Circle.

The 6 and 4 make 10, the number of Malkuth on the Tree. The Hexagram is also the sign of the Macrocosm— of Tiphareth, and of the Six Upper Sephiroth, wherefore here it is white— Spirit impacting and vivifying Matter. Six are the mid points of the planes bounding a cube, which derives from the square, and from the Cross if the Center point moves thus (*indicating third direction*). Malkuth must then be equated and refined by the 6 impacting the 4: and the link between 6 and 4 is the number of the Pentagram. In these numbers and figures are hid many revelations.





# CERTAIN LATIN WORDS ANALYZED

**Vista Interiora Terrae Rectificando Invenies  
Occultam Lapidem Veram Mediainam**

**V, I, T, R, I, O, L, U, M,**

<b>1</b>	<b>2</b>	<b>3</b>	<b>4</b>	<b>5</b>	<b>6</b>	<b>7</b>
<b>V</b>	<b>i</b>	<b>t</b>	<b>r</b>	<b>i</b>	<b>o</b>	<b>l</b>
<b>S</b>	<b>u</b>	<b>l</b>	<b>p</b>	<b>h</b>	<b>u</b>	<b>r</b>
<b>M</b>	<b>e</b>	<b>r</b>	<b>c</b>	<b>u</b>	<b>r</b>	<b>y</b>

			
<b>Subtilis</b>	<b>Aqua</b>	<b>Lux</b>	<b>Terra</b>
<b>S.A.L.T.</b>			

<b>Fiat Lux</b>			
<b>Flatus</b>	<b>Ignis</b>	<b>Aqua</b>	<b>Terra</b>
			

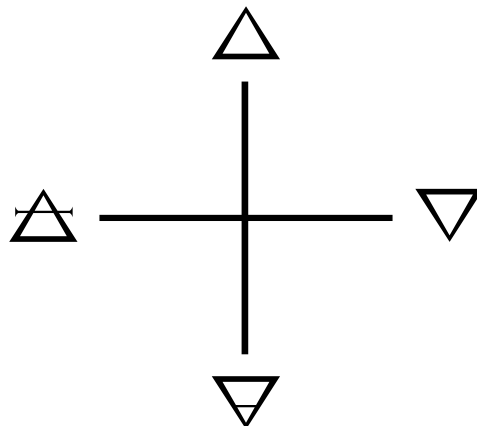

This Tablet shows the symbolic manner in which certain names have been used by our ancient brethren. You will note that the initials of this sentence make the Latin word Vitriolum, Sulphuric acid. Furthermore, the word Vitriol, Sulphur, and Mercury each consist of seven letters answering to the alchemic powers of the seven Planets.

The initials of the following sentence in Latin, the subtle fluid, the Light of the Earth, make the word S.A.L.T. salt, and further, the four words of the sentence answer to the four Elements: Subtilis, Air; Aqua, Water; Lux, Fire; and Terra, Earth. And the four words united yield 20 letters, that is, the product of four, the number of the Elements, multiplied by Five, the number of the Pentagram.

The words Fiat Lux, meaning "Let there be Light," consist of 7 letters. The letters of Fiat form the initials of Flatus, Air; Aqua, Water; Ignis, Fire; and Terra, Earth. Which four names again yield 20 letters as in the previous case. And the word Lux is formed from the angles of the Cross, LVX.

# THE SEVEN PALACES OF HOLINESS



These are the Seven Palaces of Holiness of the Briatic World. The first is the Palace of the Holy of Holies answering to Kether, Chokmah and Binah, and the Divine Name EL.

The second is the Palace of Love, answering to Chesed and the Divine Name MATZPATZ (Mem, Tzaddi, Peh, Tzaddi), which is a Temurah of Tetragrammaton.

The third is the Palace of Merit, answering to Geburah, and the Divine Name YEHEVID (Yod, Heh, Vau, Daleth).

The fourth is the Palace of Benevolence, answering to Tiphareth and TETRAGRAMMATON.

The fifth is the Palace of the Substance of Heaven, answering to Netzach and ELOHIM.

The sixth is the Palace of Severity answering to Hod and MATZPATZ.

The seventh is the Palace of Crystal Whiteness answering to Yesod and Malkuth, and the Divine Name YAH and ADONAI.

But the synthesis of these Holy Names is to be found in the word TAKLITH which is Perfection.

# THE IMAGE OF APOPHIS OR TYPHON

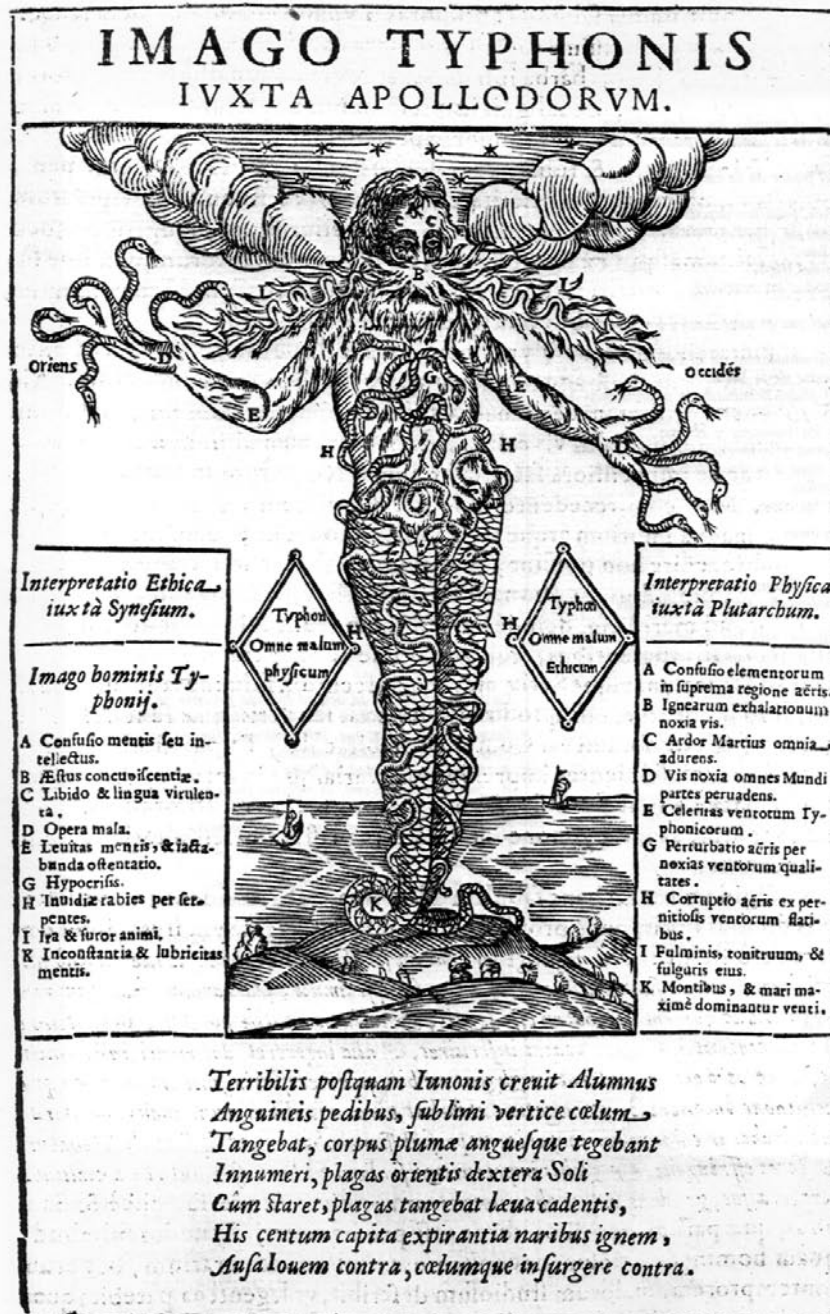

Behold the image of Apophis or Typhon:  
 Turning and turning in the widening gyre  
 The falcon cannot hear the falconer:  
 Things fall apart; the center cannot hold;  
 Mere anarchy is loosed upon the world  
 The blood-dimmed tide is loosed, and everywhere  
 The ceremony of innocence is drowned;  
 The best lack all conviction, while the worst  
 Are full of passionate intensity.

Surely some revelation is at hand;  
 Surely the Second Coming is at hand.

The Second Coming! Hardly are those words out  
 When a vast image out of Spiritus Mundi  
 Troubles my sight: somewhere in the sands of the desert  
 A shape with lion body and the head of a man,  
 A gaze blank and pitiless as the sun,  
 Is moving its slow thighs, while all about it  
 Reel shadows of the indignant desert birds.  
 The darkness drops again; but now I know  
 That twenty centuries of stony sleep  
 Were vexed to nightmare by a rocking cradle,  
 And what rough beast, its hour come round at last,  
 Slouches towards Bethlehem to be born?

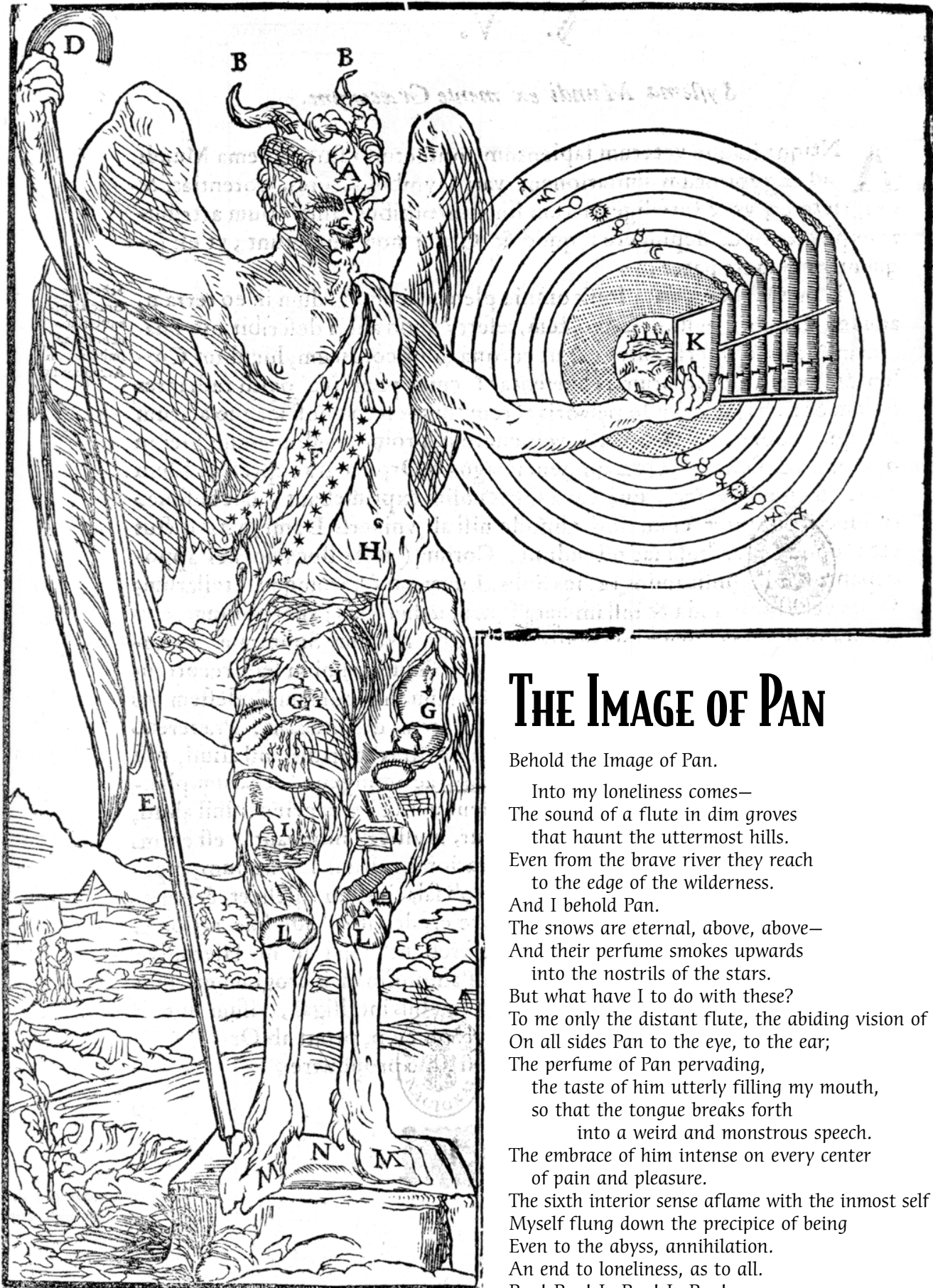

## THE IMAGE OF PAN

Behold the Image of Pan.

Into my loneliness comes—  
 The sound of a flute in dim groves  
 that haunt the uttermost hills.  
 Even from the brave river they reach  
 to the edge of the wilderness.  
 And I behold Pan.  
 The snows are eternal, above, above—  
 And their perfume smokes upwards  
 into the nostrils of the stars.  
 But what have I to do with these?  
 To me only the distant flute, the abiding vision of Pan.  
 On all sides Pan to the eye, to the ear;  
 The perfume of Pan pervading,  
 the taste of him utterly filling my mouth,  
 so that the tongue breaks forth  
 into a weird and monstrous speech.  
 The embrace of him intense on every center  
 of pain and pleasure.  
 The sixth interior sense aflame with the inmost self of Him,  
 Myself flung down the precipice of being  
 Even to the abyss, annihilation.  
 An end to loneliness, as to all.  
 Pan! Pan! Io Pan! Io Pan!

# THE LAMEN OF THE HIEREUS

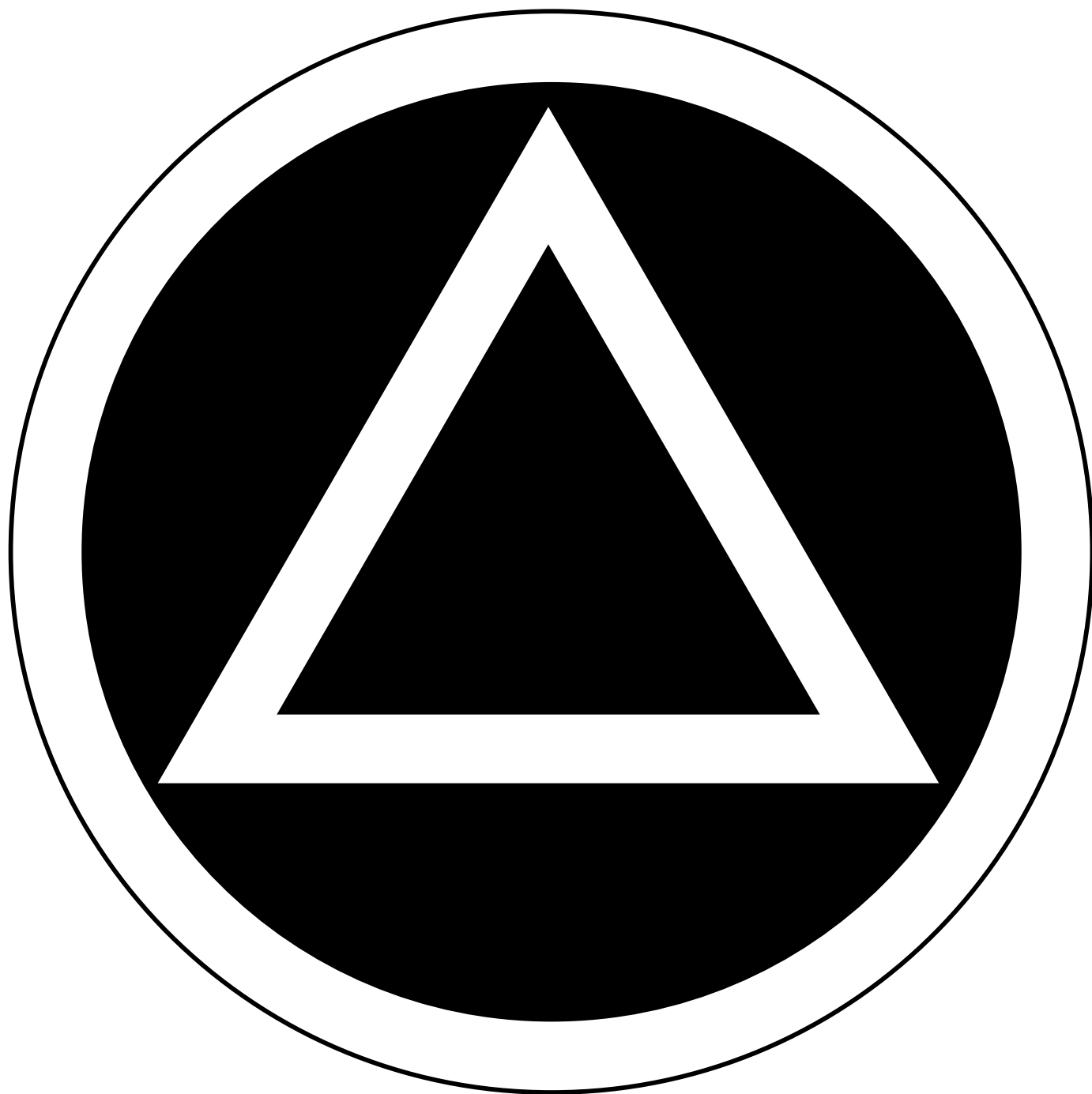

In guardianship and not in enmity, have I barred your venturing, O Philosophus. Now may it be revealed unto you that in my Lamén of Office is hidden the Key which you seek. For the Triangle in the Circle is the high symbol of the Holy Triad, and the first Three Sepheroth, and of Binah wherein is the Sphere of Saturn, Ruler of the Path Tau. Therefore do I wear it, and therefore, when you entered the Hall of the Neophytes in the O=O Rite, when first the hood-wink was raised, you beheld before you the Sword that barred and the Symbol which overcometh the barrier. The Lamén in its more special attribution to the Hieréus, has the following meanings. In the circle are the Four Sephiroth, Tiphareth, Netzach, Hod and Yesod. The first three are the angles of the Triangle inscribed within, while the sides are the Paths of Nun, Ayin and Peh, respectively. The center is the Letter Samekh, and the 25th Path. While the Wheel revolves, the hub is still. Seek ever then the center, look from without to within. Behold the Key to your Path.